

INSULATED MODULAR STRUCTURES



Low Cost Housing for High Cost Equipment

Bally's Modular Structures provide strong, insulating shelters for whatever you want to keep safe, dry, and at just the right temperature. Designed to meet your specific needs, we begin every structure with our dependable panels and finish with outstanding quality and service.



Bally Panels

- 4", 5", or 6" thicknesses.
- Our non ozone-depleting, poured-in-place urethane foam uses a low pressure expanding agent that produces 98% closed-cell insulation; allowing panels to maintain exact thicknesses and precise edges through a range of extreme temperatures.
- The Speed-Lok joining system consists of cam-mounted, hooked locking arms that engage locking pins in adjoining panels. Bolstered by steel straps foamed into panels, the Speed-Lok adds structural strength while creating a quick and simple installation.
- Bally panels are lightweight, and can be easily assembled on site or mounted on a skid. The modularity of our panel makes expansion or relocation simple.



Accessories

- **Deadbolt Option:** For installations requiring added security, we offer a Mortise deadbolt option. Even if the door hinges are removed, the door won't budge.
- **Stripcurtains & Energy efficient lighting:** Bally offers many items that help reduce your structure's energy costs.

Bally also offers a complete line of refrigeration systems.

Get started on your Bally Modular Structure!

1-800-24BALLY

www.ballyrefboxes.com



Bally Insulated Modular Structures

Roofing

- Prefabricated sectional aluminum panels are available for buildings of any length and widths up to 34'7".
- Membrane roofs offer a durable, lightweight, cost-effective alternative for most installations.

Doors

Bally has different sized doors available in many options:

- Hinged
- Double-hung hinged
- Sliding
- Overhead
- Hinged doors have 2" or 4" thick urethane insulated cores, are available in many finishes, and with observation windows.
- All doors are insulated and steel framed.

Extra large buildings

Bally structures can be assembled in any size.

- Single-tier vertical buildings up to 27'8" high.
- Multi-tier vertical as high as desired.
- Vestibules and other building additions can also be assembled out of Bally panels.

Ceiling Panels

- Widths of 11½", 23", 34½" and 46".
- Lengths up to 11'7" outdoors.
- Lengths up to 17'4" indoors.
- Optional 5" thick reinforced ceiling panels make it possible to reach lengths of 17'4" indoor without structural steel.

Windows

- 30"x 30" sealed, multi-pane "fixed" window is available to be placed in 46" wide wall panels.
- We also provide optional windows in other styles and sizes, including single-hung, double-hung, and sliding types.

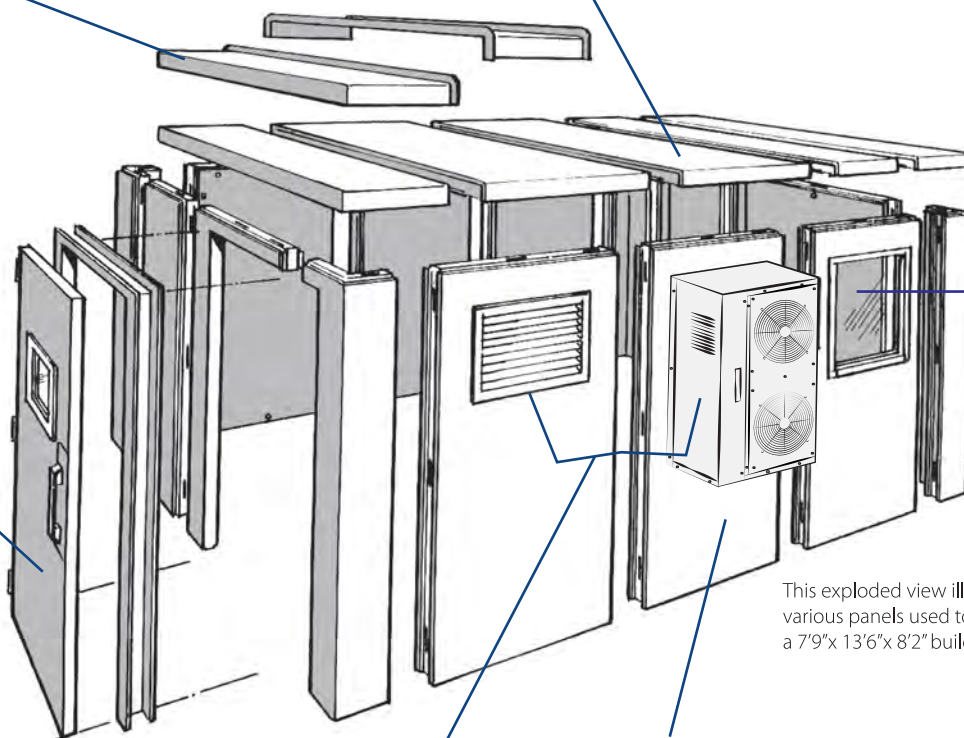

This exploded view illustrates the various panels used to assemble a 7'9" x 13'6" x 8'2" building.

Accessories

- Refrigeration Systems
- Louvers
- Panic exit hardware
- Strip curtains
- Fans and other useful accessories are available

Wall Panels

- Widths of 11½", 23", 34½" and 46".
- Various heights available.
- Panels are fully interchangeable and can be used to form partitions.
- Panels are all UL & FM listed.
- Finishes: Stainless steel, White galvanized steel, Stucco-embossed White galvanized steel, Stucco-embossed aluminum, Galvalume. Also available: custom colors and premium Kynar coating for harsh environments.

CONTACT US TODAY!

1-800-24BALLY

ballysales@ballyrefboxes.com



Bally Refrigerated Boxes, Inc.
Proudly manufactured in the U.S.A.